



DES 24M

Splittable frame for cables with and without connectors

- ▶ Multiple configurations with small and big inserts
- ▶ Frame screws in AISI304 Stainless Steel
- ▶ External gasket for IP65 included
- ▶ Strain relief according to EN 62444
- ▶ Sturdy construction IK10
- ▶ Threaded inserts version on request



The DES 24M splittable frame allow up to 40 cables with or without connector or one or two cables up to 35mm diameter to pass through electric cabinet or machines walls.

The small and big inserts can be freely positioned inside the frame.

The DES 24M frame is the base structure for the expandable MX version.

Technical data







Material: PP+GF

Flammability: self-extinguishing acc. to UL94-V0

Temperature: -40°C... +155°C (static)

Features: halogens and silicones free

Related products

-  Inserts SPG
-  Inserts SPP
-  Inserts SPP 2x
-  Inserts SPP 4x
-  Flap frame
-  DES Cover

Hydraulic punch driver HY360

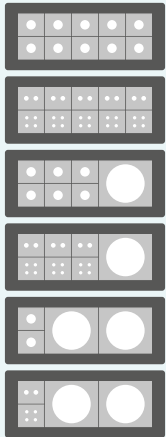
Model	Code	Some possible configurations	Cut-out [mm]	Pcs /pack
DES 24M	1731010224		114 x 40	10
Upon request:	1731991020	Set of 4 mounting screws in AISI304 with Black Dacromet finishing		10

NEW

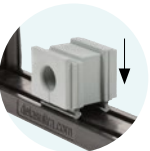

Dimensions [mm]

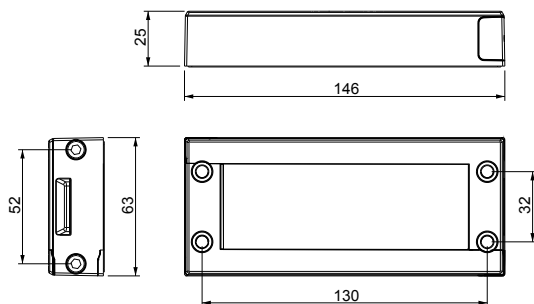

1



IP65

NEMA 12

ECOLAB



IK10

